

E1 LEFT ELEVATION
SCALE: $\frac{1}{2}'' = 1' - 0''$
RIGHT ELEVATION OPPOSITE

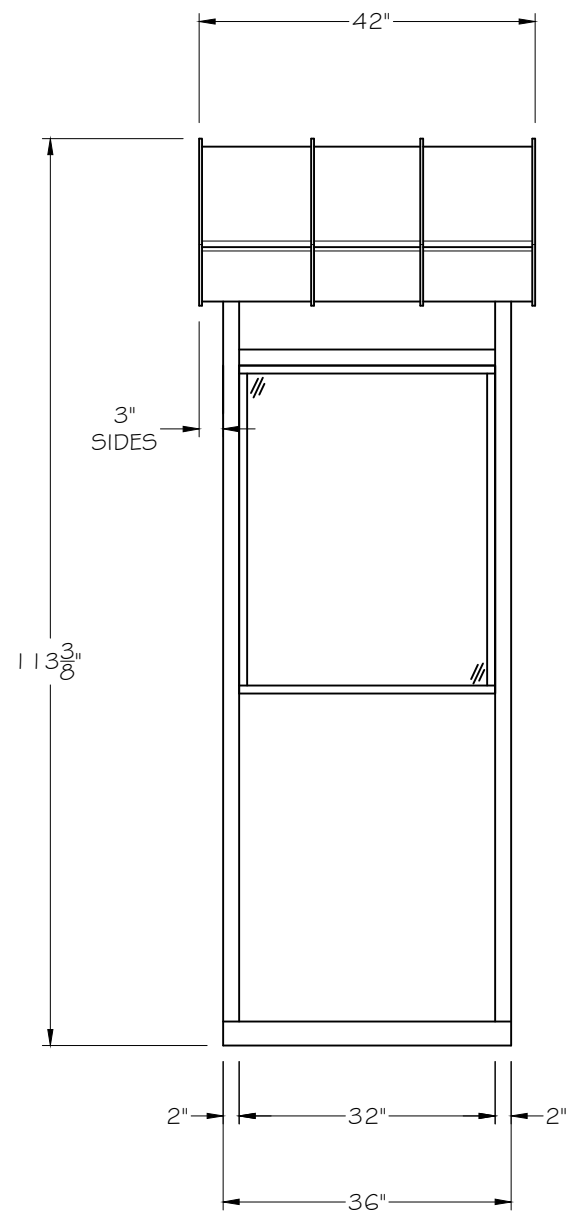

E2 FRONT ELEVATION
SCALE: $\frac{1}{2}'' = 1' - 0''$

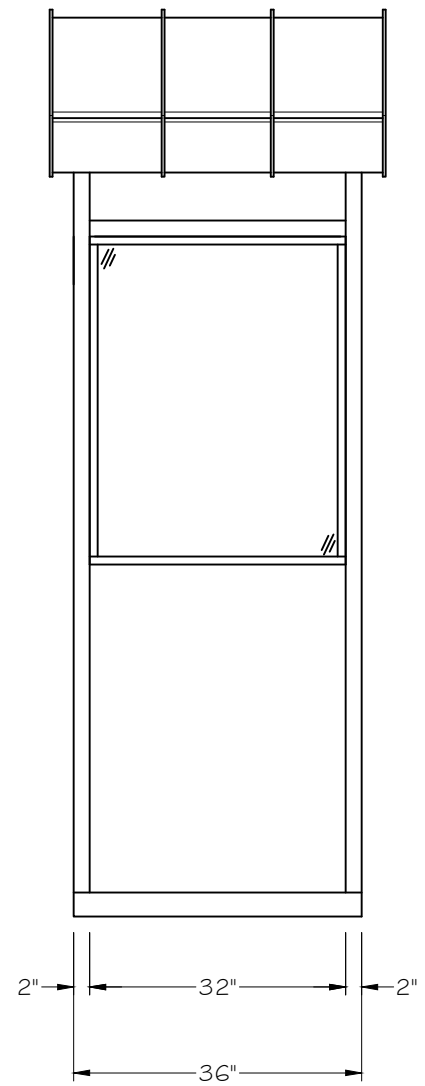

E3 REAR ELEVATION
SCALE: $\frac{1}{2}'' = 1' - 0''$

BORDER CONTROLLER

B.I.G. ENTERPRISES, INC.
9702 E. RUSH STREET
SOUTH EL MONTE, CA 91733-1730
(626) 448-1449



B.I.G. ENTERPRISES

THESE PLANS, DRAWINGS, AND/OR CADD FILES ARE THE COPYRIGHTED WORK OF B.I.G. ENTERPRISES AND IS A TRADEMARK OF B.I.G. ENTERPRISES. COPYING OR UNAUTHORIZED USE OF THESE DESIGNS OR ITS LIKENESS WILL BE PROSECUTED TO THE MAXIMUM EXTENT PERMITTED UNDER APPLICABLE STATE AND FEDERAL LAW. © B.I.G. ENTERPRISES 1988 ALL RIGHTS RESERVED

THIS IS ONLY A SAMPLE SPECIFICATION AND/OR DRAWING. WE URGE YOU TO DISCUSS YOUR PROJECT WITH A B.I.G. SALES PERSON TO INSURE THIS SAMPLE SPEC, AND/OR DRAWING MEETS YOUR NEEDS AND TO VERIFY ALL CODES WHERE YOUR UNIT WILL BE INSTALLED ARE ACCURATELY IDENTIFIED IN THE DRAWING, AND/OR SPEC.

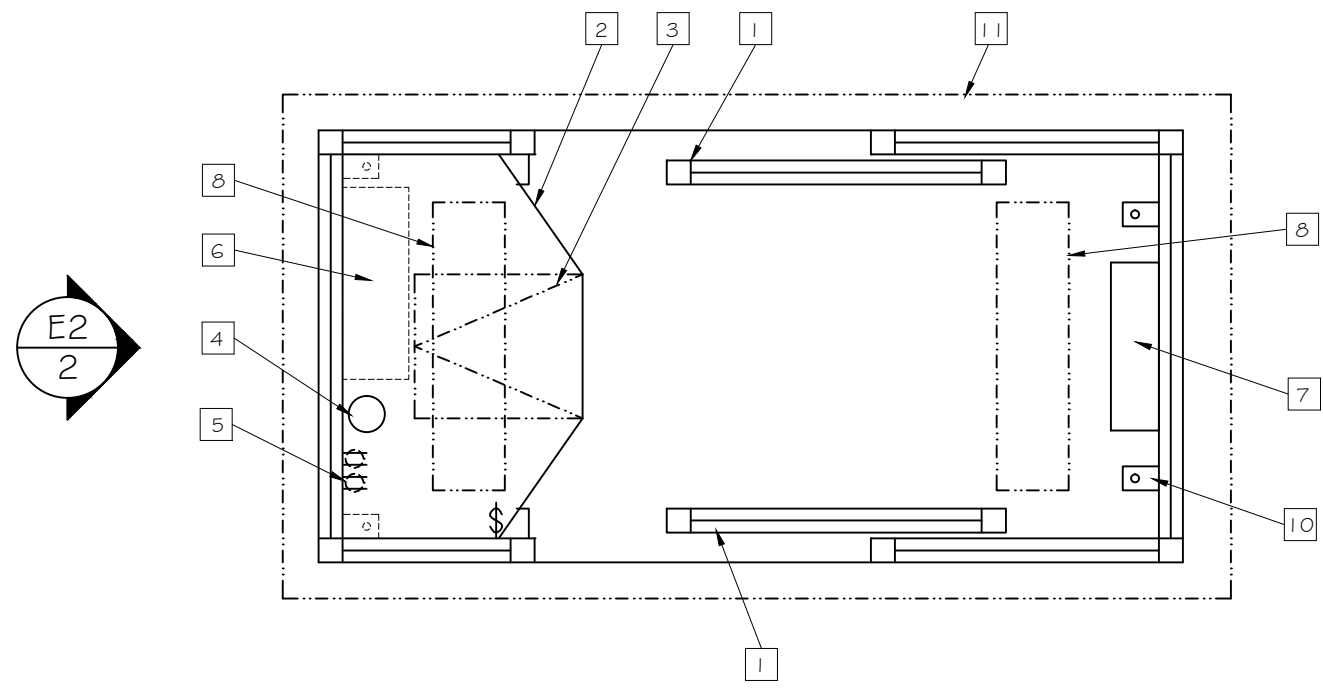

- 1 SLIDING DOOR
- 2 20" SHELF
- 3 UTILITY DRAWER
- 4 3" CORD ACCESS HOLE
- 5 RECEPTACLES
- 6 HEATER
- 7 LOAD CENTER
- 8 FLUORESCENT FIXTURE
- 9 (not used)
- 10 ANCHOR CLIP
- 11 OVERHANG

FLOOR PLAN
SCALE $\frac{3}{4}'' = 1' - 0''$

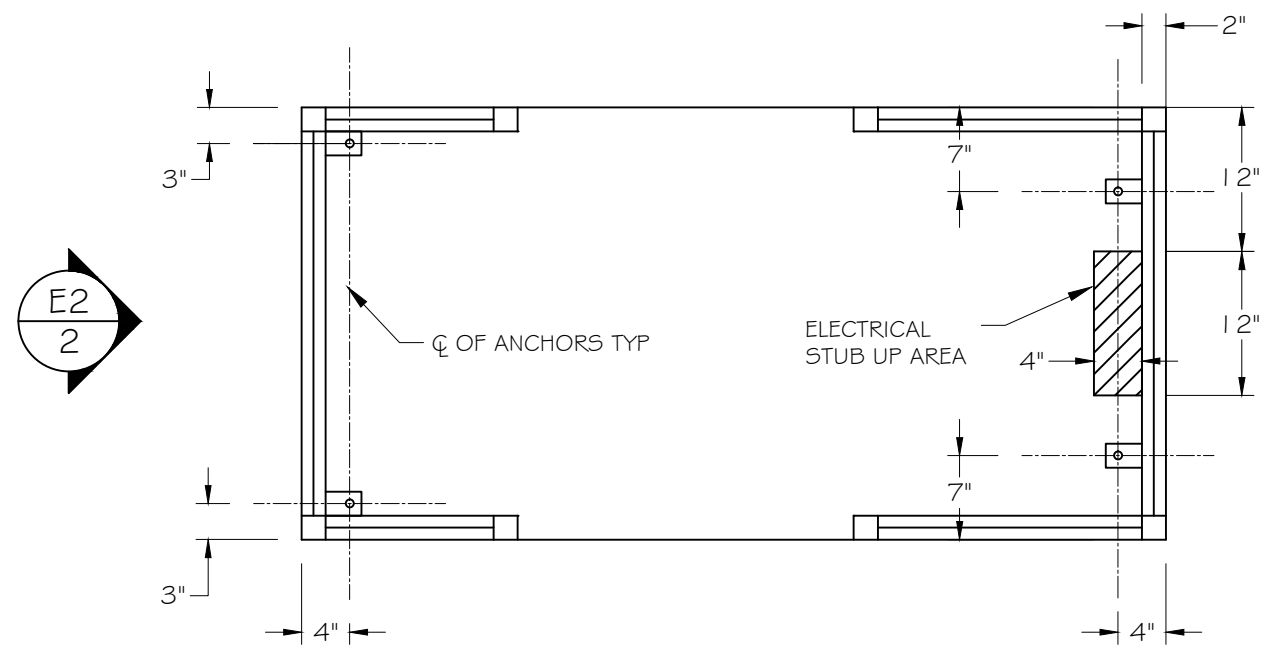

**ELECTRICAL STUB
AREA PLAN**
SCALE $\frac{3}{4}'' = 1' - 0''$

B.I.G. ENTERPRISES
THESE PLANS, DRAWINGS, AND/OR CADD FILES ARE THE
COPYRIGHTED WORK OF B.I.G. ENTERPRISES AND IS A
TRADEMARK OF B.I.G. ENTERPRISES. COPYING OR UNAUTHORIZED
USE OF THESE DESIGNS OR ITS LIKENESS WILL BE PROSECUTED
TO THE MAXIMUM EXTENT PERMITTED UNDER APPLICABLE STATE
AND FEDERAL LAW. © B.I.G. ENTERPRISES 1988 ALL RIGHTS
RESERVED

BORDER CONTROLLER

B.I.G. ENTERPRISES, INC.
9702 E. RUSH STREET
SOUTH EL MONTE, CA 91733-1730
(626) 448-1449

