

E1 LEFT ELEVATION
SCALE $\frac{1}{2}'' = 1' - 0''$

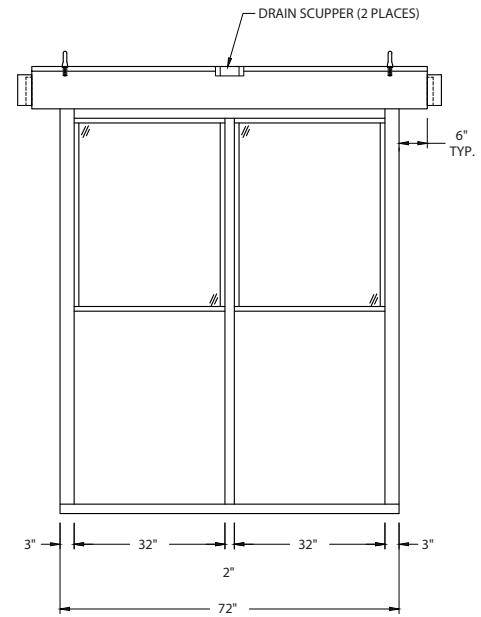

E2 FRONT ELEVATION
SCALE $\frac{1}{2}'' = 1' - 0''$

B.I.G. ENTERPRISES
THESE PLANS, DRAWINGS, AND/OR CADD FILES ARE THE COPYRIGHTED WORK OF B.I.G. ENTERPRISES AND IS A TRADEMARK OF B.I.G. ENTERPRISES. COPYING OR UNAUTHORIZED USE OF THESE DESIGNS OR ITS LIKENESS WILL BE PROSECUTED TO THE MAXIMUM EXTENT PERMITTED UNDER APPLICABLE STATE AND FEDERAL LAW. © B.I.G. ENTERPRISES 1988 ALL RIGHTS RESERVED

THIS IS ONLY A SAMPLE SPECIFICATION AND/OR DRAWING. WE URGE YOU TO DISCUSS YOUR PROJECT WITH A B.I.G. SALES PERSON TO INSURE THIS SAMPLE SPEC. AND/OR DRAWING MEETS YOUR NEEDS AND TO VERIFY ALL CODES WHERE YOUR UNIT WILL BE INSTALLED ARE ACCURATELY IDENTIFIED IN THE DRAWING, AND/OR SPEC.

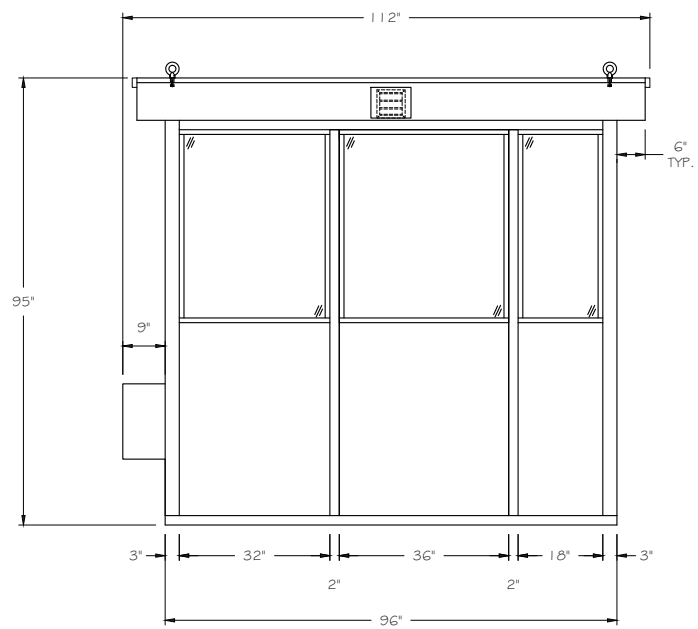

E3 RIGHT ELEVATION
SCALE $\frac{1}{2}'' = 1' - 0''$



E4 REAR ELEVATION
SCALE $\frac{1}{2}'' = 1' - 0''$

B.I.G. ENTERPRISES
THESE PLANS, DRAWINGS, AND/OR CADD FILES ARE THE
COPYRIGHTED WORK OF B.I.G. ENTERPRISES AND IS A
TRADEMARK OF B.I.G. ENTERPRISES. COPYING OR UNAUTHORIZED
USE OF THESE DESIGNS OR ITS LIKENESS WILL BE PROSECUTED
TO THE MAXIMUM EXTENT PERMITTED UNDER APPLICABLE STATE
AND FEDERAL LAW. B.I.G. ENTERPRISES 1306 ALL RIGHTS
RESERVED

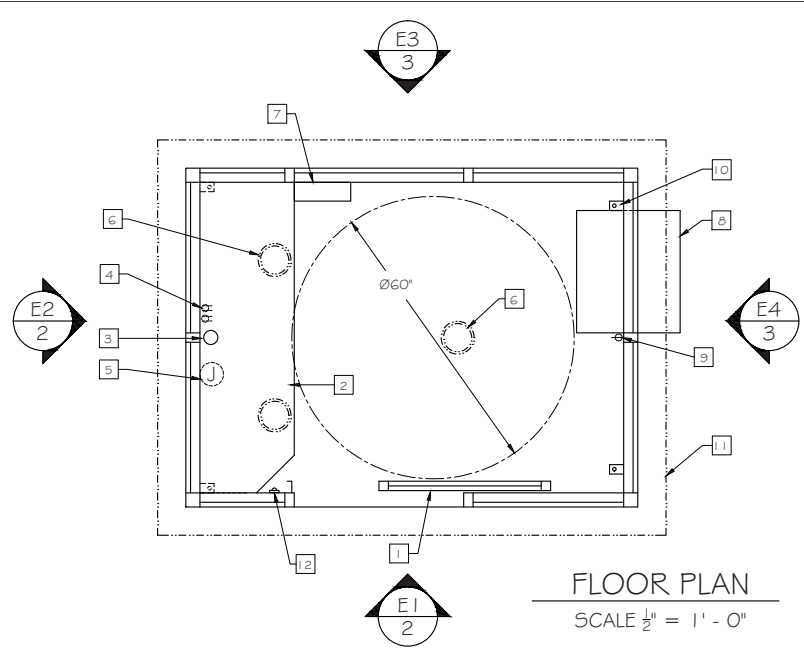

FLOOR PLAN
SCALE $\frac{1}{2}'' = 1' - 0''$

LEGEND:

- | | |
|---|--|
| 1 36" x 80" SLIDING DOOR - GENERAL NOTE #5 | 8 AIR CONDITIONER - GENERAL NOTE #10 |
| 2 20" SHELF - GENERAL NOTE #11 | 9 A/C RECEPTACLE |
| 3 3" CORD ACCESS HOLE | 10 ANCHOR CLIP (4 PLACES) - GENERAL NOTE #13 |
| 4 RECEPTACLES - GENERAL NOTE #9 | 11 6" OVERHANG - GENERAL NOTE #3 |
| 5 DATACOMM. JUNCTION BOX - GENERAL NOTE #9a | 12 OCCUPANCY SENSOR LIGHT SWITCH |
| 6 FLUORESCENT FIXTURES - GENERAL NOTE #8 | |
| 7 LOAD CENTER - GENERAL NOTE #7 | |

B.I.G. ENTERPRISES
THESE PLANS, DRAWINGS, AND/OR CADD FILES ARE THE
COPYRIGHTED WORK OF B.I.G. ENTERPRISES AND IS A
TRADEMARK OF B.I.G. ENTERPRISES. COPYING OR UNAUTHORIZED
USE OF THESE DESIGNS OR ITS LIKENESS WILL BE PROSECUTED
TO THE MAXIMUM EXTENT PERMITTED UNDER APPLICABLE STATE
AND FEDERAL LAW. © B.I.G. ENTERPRISES 1988 ALL RIGHTS
RESERVED

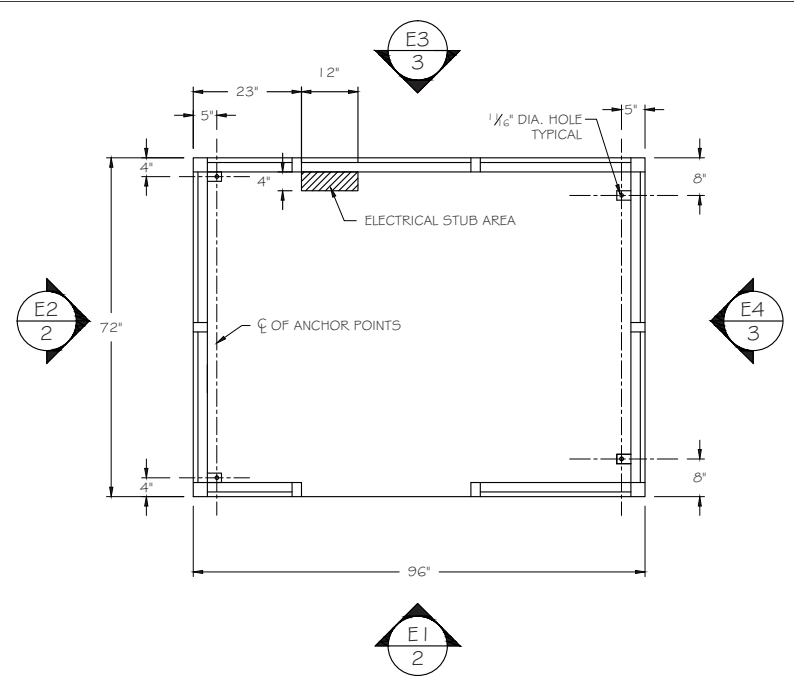

STUB UP AREA &
ANCHOR LOCATIONS
SCALE $\frac{1}{2}'' = 1' - 0''$

INDICATES OPENING THROUGH FLOOR